

**-60°C Freezer**

Model		DW-60W138	DW-60W258	DW-60W388	
Technical Data	Cabinet Type	Chest	Chest	Chest	
	Climate Class	N	N	N	
	Cooling Type	Direct cooling	Direct cooling	Direct cooling	
	Refrigerant	R600a/R1150	R600a/R1150	R600a/R1150	
	Sound Level((dB(A))	43	43	43	
Performance	Cooling performance(°C)	-60	-60	-60	
	Temperature Range(°C)	-30 ~ -60	-30 ~ -60	-30 ~ -60	
Control	Controller	Microprocessor	Microprocessor	Microprocessor	
	Display	LED	LED	LED	
Electrical Data	Power Supply (V/HZ)	220 ~ 240/50	220 ~ 240/50	220 ~ 240/50	
	Power (W)	370	410	420	
	Electrical Current (A)	3.0	3.0	3.5	
Dimension	Capacity(L/Cu.Ft)	138/4.9	258/9.1	388/13.7	
	Net/Gross Weight (approx)	kg	62/75	88/108	105/130
		lbs	137/165	194/238	232/287
	Interior Dimension(W*D*H)	mm	580*445*620	1000*445*620	1450*445*620
		in	22.8*17.5*24.4	39.4*17.5*24.4	57.1*17.5*24.4
	Exterior Dimensions (W*D*H)	mm	790*770*950	1210*770*950	1655*770*950
		in	31.1*30.3*37.4	47.6*30.3*37.4	65.2*30.3*37.4
	Packing Dimensions (W*D*H)	mm	815*800*990	1255*800*990	1695*800*990
		in	32.1*31.5*39	49.4*31.5*39	66.7*31.5*39
	Container Load(20'/40'/40'H)		28/56/56	22/46/46	14/28/28
Alarms	High/Low Temp	Y	Y	Y	
	Sensor Error	Y	Y	Y	
Accessories	Caster	Y	Y	Y	
	Porthole	Y	Y	Y	
Others	Certification	CE	CE	CE	

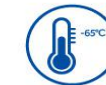

DW-60W138



-60°C deep freezing freezers quickly freeze sea food products such as tuna fish, Australian lobster, and top quality beef to retain their original taste, structure and freshness.



Super low sound operation: noise cancelling technology yields a sound level of less than 43 dba.



Multiple alarm system includes temperature alarms, and sensor error alarm. Alarm message can be sent via instant message.



HC refrigerant system is optimized to improve refrigeration efficiency by 30 %, and save energy by about 50%.

The series of freezers is designed for storage of tuna, Australian lobster, salmon, south American shrimps, Argentina red shrimp, top quality beef, kanpachi, octopus, yellow tail, bonito fish, grouper, and fugu rubripes. They are popular among professional oceanic fisherman, sea food distributors, specialty sea food stores and sushi restaurants.

**Haier Medical and Laboratory Products Co., Ltd**

Brand Building, Haier Industrial Park, No. 1  
Haier Road, Qingdao, 266101, P.R. China  
Tel: +86-0532-88936011 / 5955  
Website: www.haiermedical.com

Ihr Fachhändler:  
Buchner Labortechnik  
Hochstr. 1  
85276 Pfaffenhofen  
Tel.: +49 (0)8441 803060  
Fax: +49 (0)8441 803071  
Mail: info@Laborgeraete.com  
www.Laborgeraete.com



## Safer by Design

Single compressor auto cascade refrigeration system provides high efficient cooling power. Insulation thickness is 100 mm for optimal protection of cold temperature and saving energy.



Creative dual seals design retains cold temperature more effectively, and eliminates condensation on gaskets.



Interior material is certified food grade 304 stainless steel, ensuring safe contact between food and interior liner.



Interior lock design ensures product safety. Lockable casters permit ease of installation and maneuvering.



Water proof digital control delivers precise temperature for storage. Display and control system are easy to use.

### PRODUCT ADVANTAGES



Dual-seal design



Imported brand fan



Imported brand compressor



Digital temperature control display

### DW-60W138 | TYPICAL PERFORMANCE CHARACTERISTICS IN 25°C AMBIENT

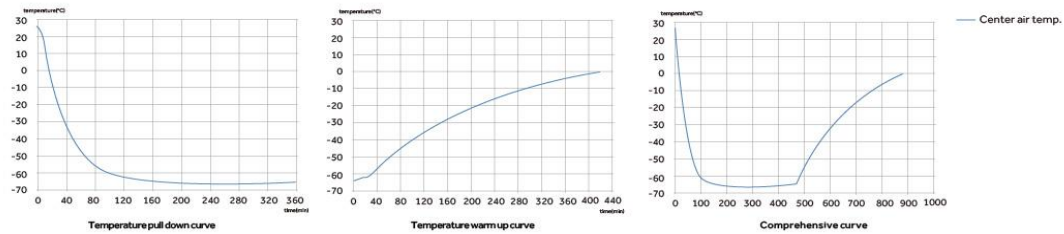

### DW-60W258 | TYPICAL PERFORMANCE CHARACTERISTICS IN 25°C AMBIENT

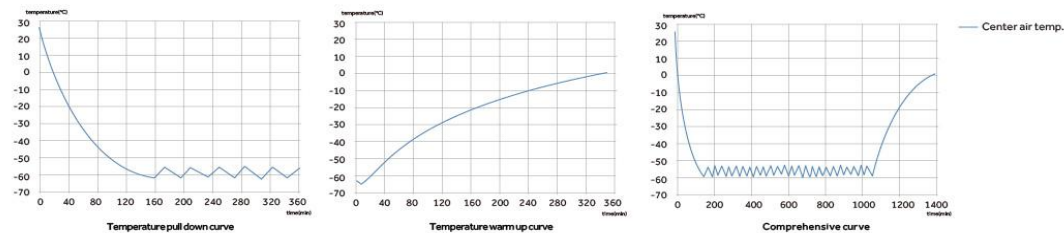

### DW-60W388 | TYPICAL PERFORMANCE CHARACTERISTICS IN 25°C AMBIENT

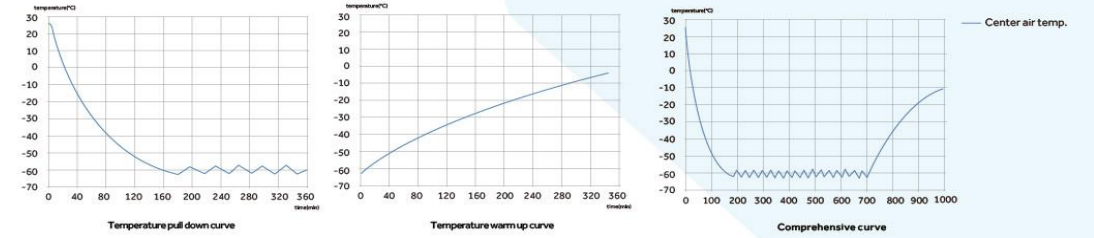

### PRODUCT DIMENSION DRAWING

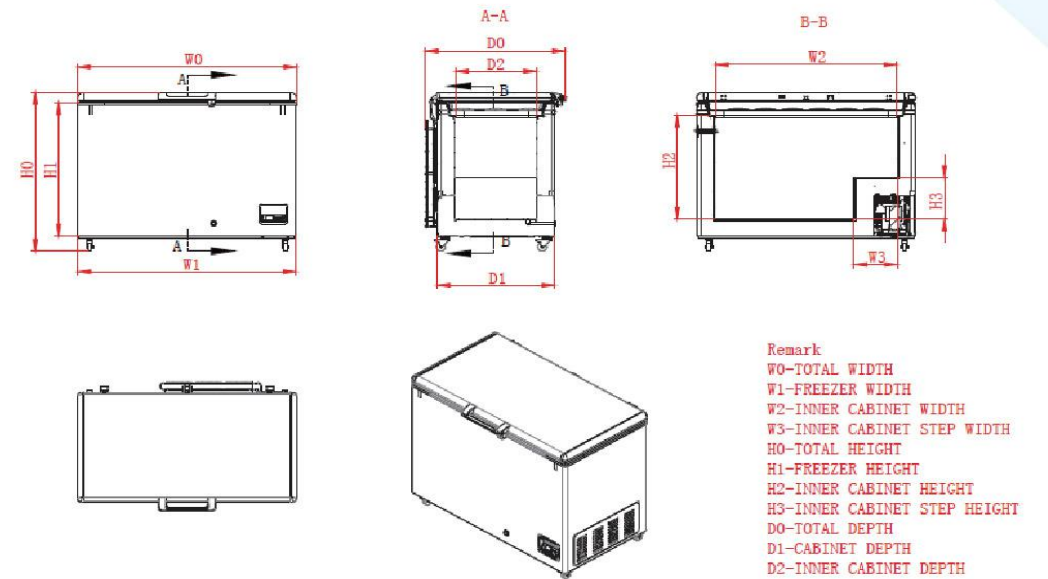

MODEL	CODE	W0	W1	W2	W3	H0	H1	H2	H3	D0	D1	D2
DW-60W138		790	785	580	240	950	797	620	250	770	650	445
DW-60W258		1210	1205	1000	240	950	797	620	250	770	650	445
DW-60W388		1655	1650	1450	240	950	797	620	250	770	650	445